

**KOENIG & BAUER**

**Wartungspaket Lackiermaschine 470 /  
Maintenance package coater 470**

**B03662**

**D/E**

## **Urheberschutzvermerk**

Das Urheberrecht an diesem Dokument verbleibt bei der Koenig & Bauer MetalPrint GmbH.

Das Dokument enthält Teilenummern, Zeichnungen und Fotos technischer Art, die weder vollständig noch teilweise vervielfältigt, verbreitet oder zu Zwecken des Wettbewerbs unbefugt verwertet oder weitergegeben werden dürfen.

Die Teilenummern, Zeichnungen und Fotos die in der Dokumentation enthalten sind, werden unseren Kunden auf streng vertraulicher Basis mitgeteilt.

Treffen Sie die notwendigen Maßnahmen, um den vertraulichen Charakter beizubehalten.

## **Copyright notice**

The copyright for this document remains with Koenig & Bauer MetalPrint GmbH.

The document contains part numbers, technical drawings and photographs that may not be copied, distributed or used without authorization for the purpose of competition or be disclosed to any third party, either in whole or in part.

The part numbers, technical drawings and photographs contained in the documentation are disclosed to our customers on a strictly confidential basis.

You must ensure that this information is kept confidential.

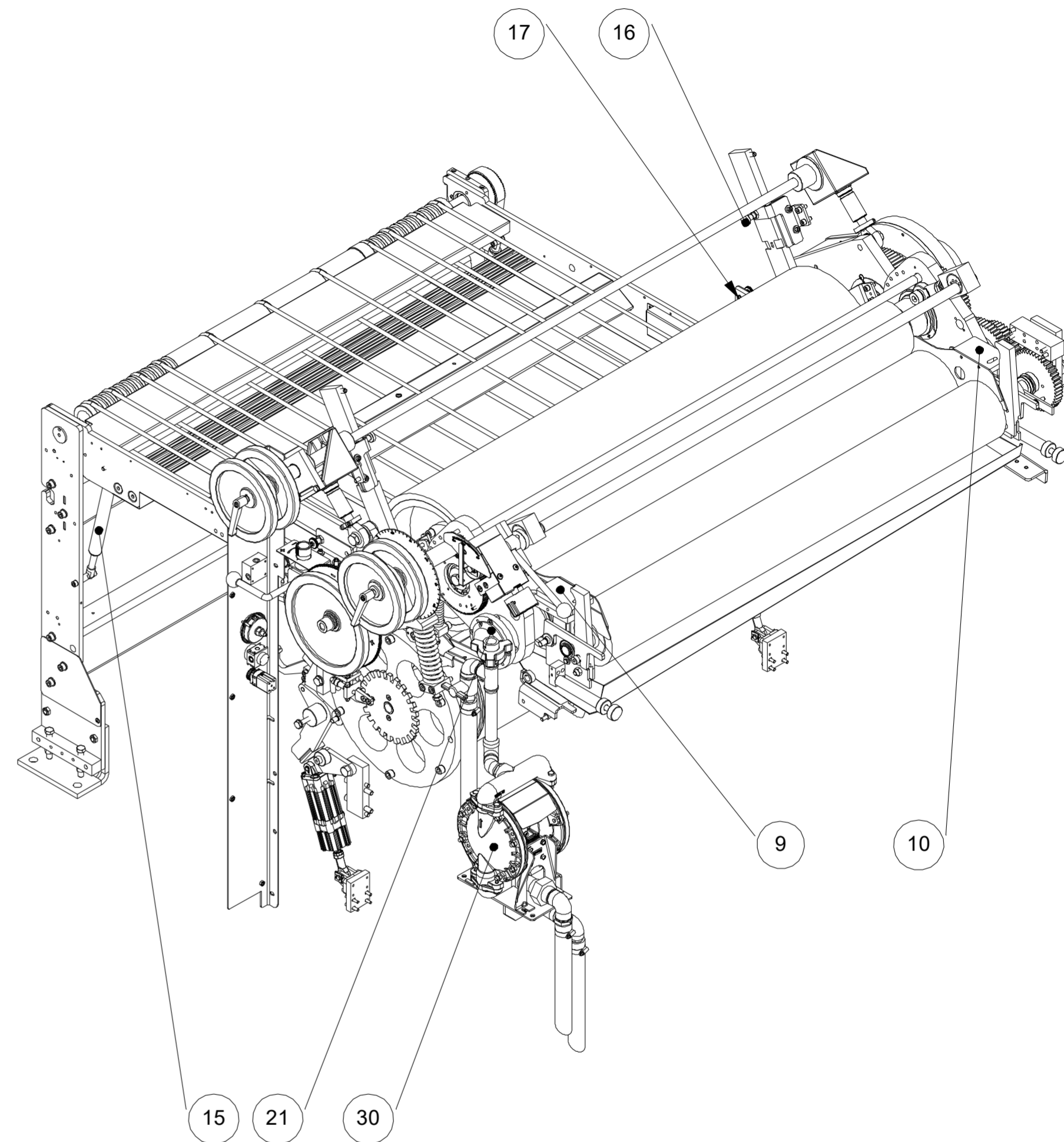
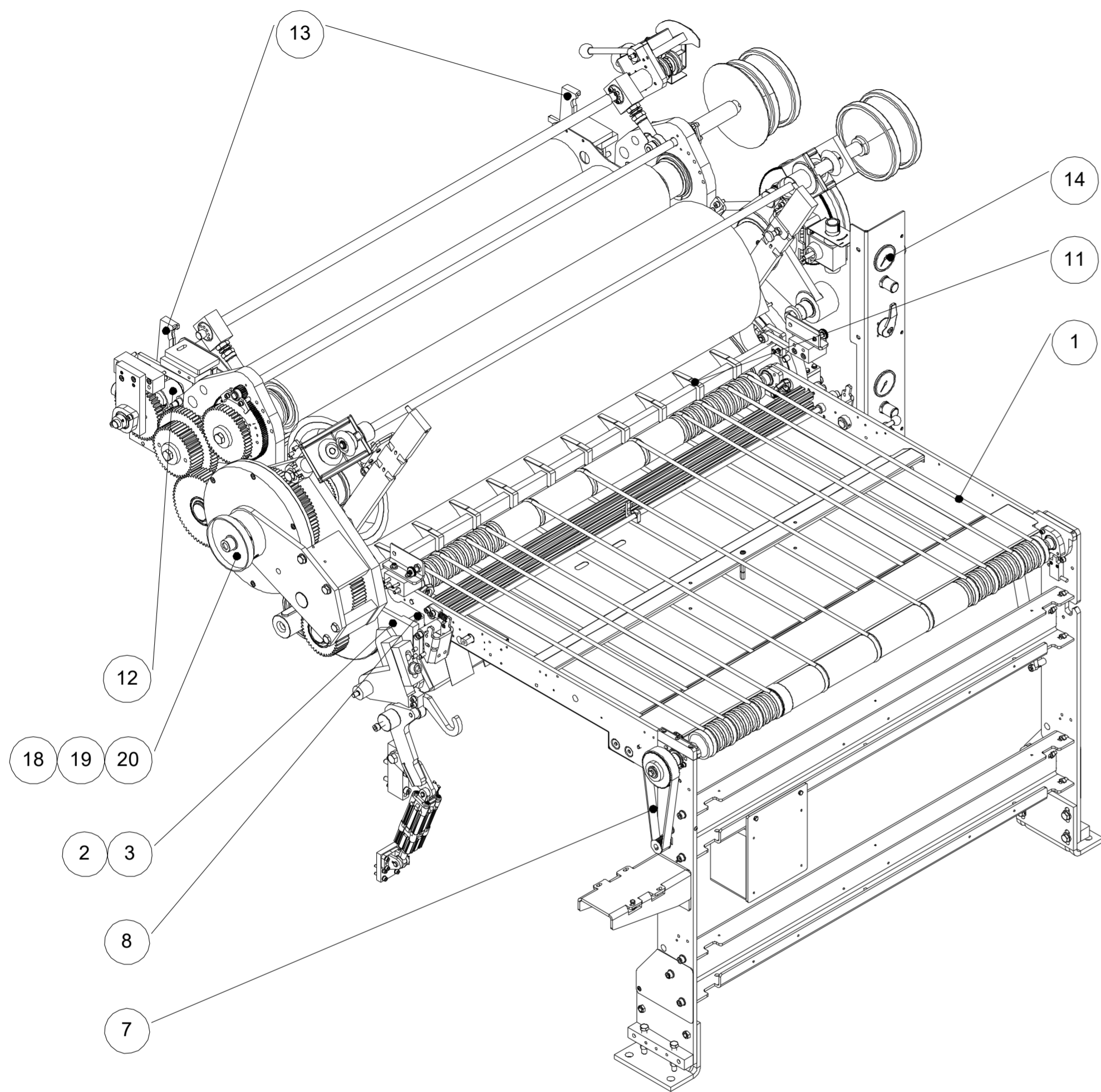

The following parts are not included

Pos. 1

**Round belt A76588 (11x)**

**Round belt FDA A70214 (11x)**

The following parts are not included

Pos. 2 + 3

**Gasket plate --> Standard main blade  
29778 + 29779 (in each case 1x)**

**Gasket plate --> Flexo blade  
D02139 + D02140 (in each case 1x)**

Pos. 50-52

**Sensor for sliding cover**

Rev.	Datum	Name	Freimasstoleranz DIN ISO	Gewicht 0	Werkstueck- kanten DIN 6784	Werkstoff	Aenderung
erstellt	29.09.2023	FST		Massstab 1:10			
geprueft			Oberflaeche DIN ISO 1302	Blatt 1 von 1	Ers. durch	Zeichnungs- nummer	Rev.
Schutzvermerk nach ISO 16016 beachten				Format DIN A2	Ers. fuer	<b>B03662-</b>	
<b>KOENIG &amp; BAUER</b>				<b>MAINTENANCE PACKAGE COATING MACHINE 470</b>			
<small>Koenig &amp; Bauer MetalPrint GmbH · Wernerstrasse 119-129 · D-70435 Stuttgart Tel.: +49-711-69971-0 · Fax: -637 · E-Mail: info-metalprint@koenig-bauer.com</small>							

## B03662 WARTUNGSPAKET LACKIERMASCHINE 470 / MAINTENANCE PACKAGE COATER 470

Pos Item	SF SF	Menge Qty	Benennung Designation	Teile Nr. Part No.
000		1	WARTUNGSPAKET LACKIERMASCHINE 470; MAINTENANCE PACKAGE COATER 470	B03662
7		1	ZAHNRIEMEN;	D05987



8		1	TOOTHED BELT RAKELMESSER;	14185
---	--	---	------------------------------	-------

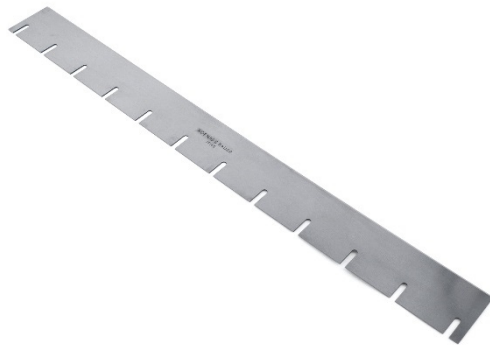

SCRAPER BLADE

Pos Item	SF SF	Menge Qty	Benennung Designation	Teile Nr. Part No.
9		1	ABSTREIFER;	17430



10		1	STRIPPER ABSTREIFER;	17431
----	--	---	-------------------------	-------



STRIPPER

Pos Item	SF SF	Menge Qty	Benennung Designation	Teile Nr. Part No.
11		10	FÜHRUNG;	29958

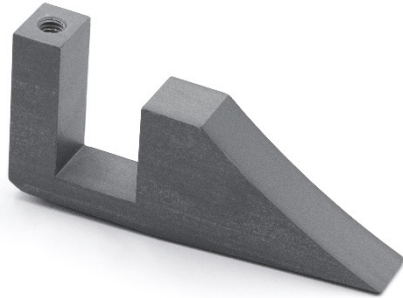

GUIDE

12		1	BOGENZAHNKUPPLUNG;	N2159
----	--	---	--------------------	-------



BARREL-TOOTH COUPLING

Pos Item	SF SF	Menge Qty	Benennung Designation	Teile Nr. Part No.
13		2	HEBEL;	29644



LEVER

14		2	MANOMETER; MANOMETER	N2581
15		2	GASDRUCKFEDER; GAS PRESSURE SPRING	D68532
16		2	RASTBOLZEN; RATCHET PIN	N2106
17		2	RASTBOLZEN; INDEXING BOLT	D12314
18		2	WELLENDICHTRING;	N2603



SHAFT PACKING RING

Pos Item	SF SF	Menge Qty	Benennung Designation	Teile Nr. Part No.
19		2	O-RING;	N2329

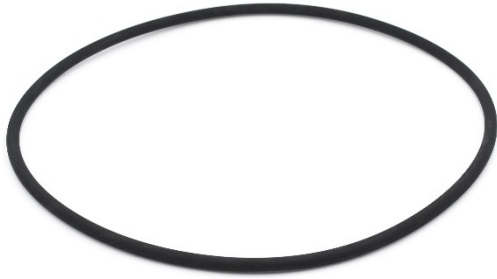

20		2	O-RING; O-RING;	N2117
----	--	---	--------------------	-------



21		2	O-RING; O-RING; O-RING	N2286
----	--	---	------------------------------	-------

30		1	DOPPELMEMBRANPUMPE Aro; DOUBLE DIAPHRAGM PUMP	D11363
----	--	---	--	--------

Pos Item	SF SF	Menge Qty	Benennung Designation	Teile Nr. Part No.
31		1	LACKSIEB;	26255

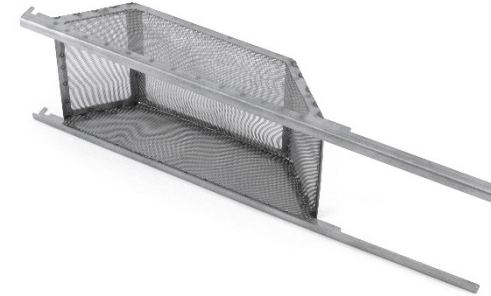

50		1	LACQUER STRAINER SICHERHEITSSENSOR; SAFETY SENSOR	A57920
51		1	BETÄTIGER; COMMANDER	A57965
52		1	KABELDOSE; CABLE BOX	A02378